

Profile

- Accuracy class ±0.1°
- Output circuit sin/cos 1 V_{SS}
- Status LED display
- Robust metal housing
- Scale MBR100
- Signal period 1000 μm

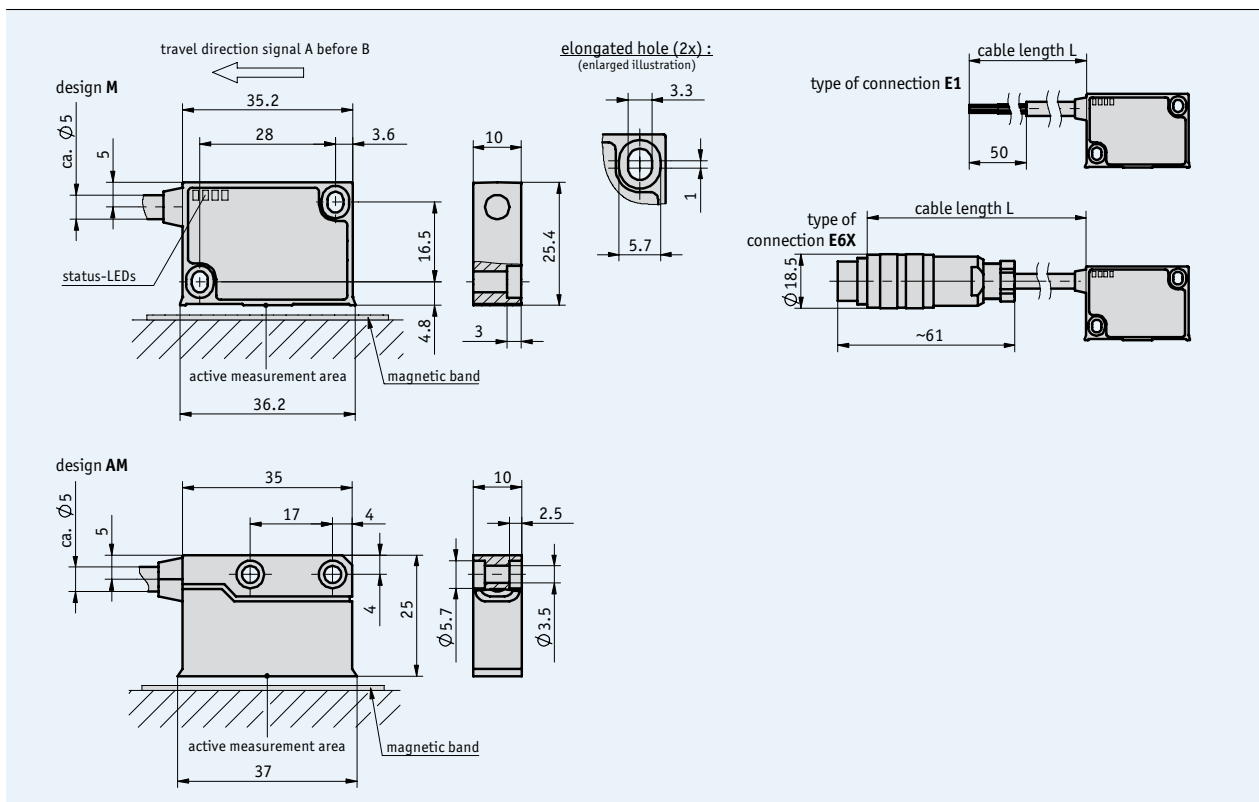

Mechanical data

Feature	Technical data	Additional information
Scale embodiment	MBR100	
System accuracy	max. 1 % related to division period	
Sensor/ring reading distance	0.1 ... 0.4 mm 0.1 ... 0.2 mm	with reference signal 0, IA, ID with reference signal RB
Circumferential speed	max. 20 m/s	
Housing	zinc die-cast	
Sensor cable	PUR	drag chain-compatible
Operating temperature	-10 ... +70 °C	
Storage temperature	-30 ... +80 °C	
Humidity	100 % rh	condensation permitted
Protection category	IP67	
Vibration resistance	<200 m/s ² (50 ... 2000 Hz)	

Electrical data

Feature	Technical data	Additional information
Operating voltage	10.5 ... 30 V DC 5 V DC ±5 %	reverse-polarity protection on UB no reverse-polarity protection on UB
Current consumption	<25 mA <50 mA	with 24 V with 5 V
Type of connection	flying leads round connector	
Output circuit	1 V _{SS}	
Output signals	sin, cos, /sin, /cos, I, /I, or R, /R	
Pulse width of reference signal	see the drawing of the signal shape	
Interference protection class	3	according to IEC 801
Real-time requirement	real-time signal processing	
Signal amplitude	1 V _{SS} ±10 %	at 0-70 °C with RA = 120 Ohm to 1 kOhm
Output impedance	0 Ohm (Rload >75 Ohm)	short-circuit-proof
Offset sine/cosine	2.5 V ±100 mV UB/2 ±100 mV	
Phasing sine/cosine	90° ±1°; < ±3° (20 kHz)	
Phasing of reference signal	sin 45, cos 135°	
Signal period	1000 µm	

Signal forms

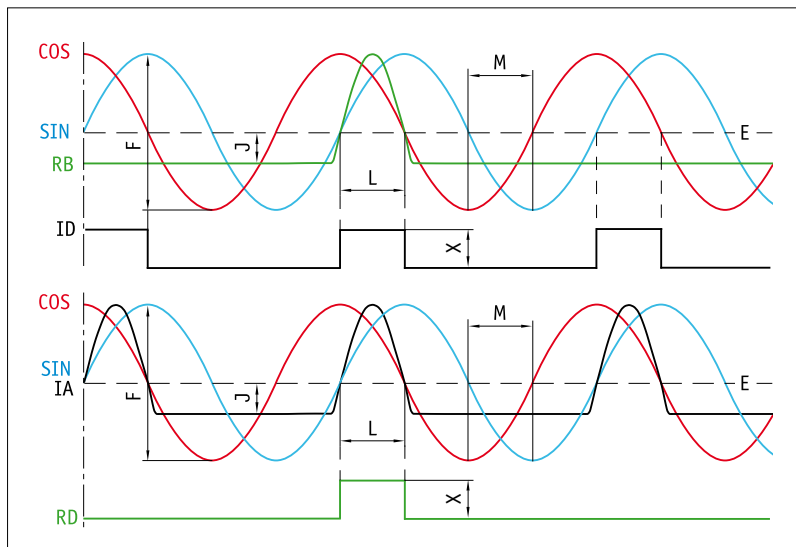

E: reference voltage 2.5 V
F: 1 V_{SS} ±10 %
J: ≥0.2 V
L: 100° ±20°
M: 90° ±1.0° / < ±3° (25 kHz)
X: 1 V_{SS}

5.4

Pin assignment

without reference signal

Signal	E1	E6X
GND	black	1
sin	red	2
/sin	orange	3
cos	yellow	4
/cos	green	5
+UB	brown	6
N.C.		7

with reference signal

Signal	E1	E6X
sin	red	1
cos	yellow	2
index	blue	3
+UB	brown	4
GND	black	5
/sin	orange	6
/cos	green	7
/index	violet	8

Mounting instruction

On systems with reference points on the magnetic ring, please ensure the correct alignment of the sensor and band.

Reference signal	O, IA, ID	RB, RD
A, Sensor/band reading distance	max. 0.4 mm	max. 0.2 mm
B, Lateral offset	max. ±2 mm	max. ±0.5 mm
C, Misalignment	<±3°	<±1°
D, Longitudinal tilt	<±1°	<±1°
E, Lateral tilt	<±3°	<±1°

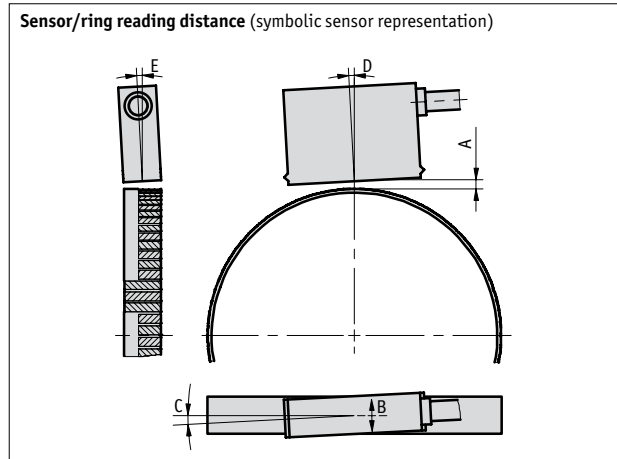

Order

Order note

For the "AM" design feature with reference signal "O", a special version, SA09, is available on request. Housing connected to screen, twisted-pair sensor cable.

Order table

Feature	Order data	Specifications	Additional information
Operating voltage	10	10.5 ... 30 V DC	
	5	5 V DC ±5 %	
Design	M	metal housing with status LEDs	
	AM	metal housing without status LEDs	
Type of connection	E1		
	E6X		cable extensions on request
Cable length L	...	1 ... 20 m, in steps of 1 m	
		others on request	
Reference signal	O	without	
	IA	index periodic (analog)	index signal every 1 mm
	ID	index periodic (digital)	index signal every 1 mm
	RB	fixed, band side (analog)	
	RD	fixed, band side (digital)	

Order code

LE100/1 - - - - - - -

A B C D E S

Scope of delivery: LE100/1, User information, Allen fastening screws M3 x 14 mm ISO 4762, lock washers M3 DIN 7980, strain relief for sensor cable, distance gage 0.2 mm

Additional information:

Short Description, Technical Details
Product Overview

Page 140 cont.
Page 4 cont.